

Turbo™
Fiberglass Cone Fan and Grill Fan
36" Direct Drive

Installation & Operator's Instruction Manual

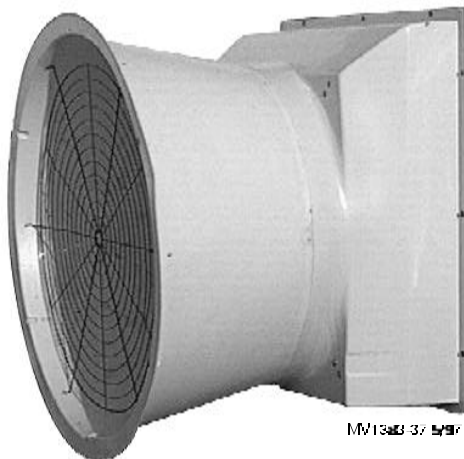

Chore-Time TURBO™ Fan Extended Warranty

Chore-Time Equipment warrants new TURBO™ Fans and components manufactured by it to be free from defects in material or workmanship from the date of initial installation by the original purchaser until expiration of the appropriate period set forth below. If such a defect is found by Chore-Time to exist within the applicable period, Chore-Time will, at its option, (a) repair or replace such product free of charge, F.O.B. the factory of manufacture, or (b) refund to the original purchaser the original purchase price, in lieu of such repair or replacement. The extended warranty is provided to the original purchaser for the following periods:

- *1. **TURBO™ Fan** fiberglass housings and cast aluminum blades for as long as the original purchaser owns the product.
- *2. **TURBO™ Fan** motors and bearings - for two years from date of installation.
- *3. **TURBO™ Fan** components, including plastic shutters and polyethylene cones - for three years from date of installation.

Conditions and limitations:

1. Original purchaser must give prompt notice of any defect to obtain warranty service. The notice must be mailed to Chore-Time Equipment, P.O. Box 2000, Milford, Indiana, 46542-2000, U.S.A. The remedies provided under this warranty, if applicable, shall be provided within a reasonable time after Chore-Time's receipt of such notice.
2. The product must be purchased from an authorized Chore-Time distributor or dealer and installed, operated and maintained in accordance with instructions published by Chore-Time Equipment or warranty is void.
3. Warranty is void if all structural and operational parts and components of the product were not supplied by Chore-Time Equipment.
4. Failure, damage, or malfunction resulting from misuse, abuse, negligence, alteration, accident, lack of proper maintenance, improper or insufficient power sources or electrical connections, impact of foreign objects, tornado, hurricane, other violent storm, flood, fire, pollutants, chemicals, acts of God, or other causes outside the reasonable control of Chore-Time shall not be considered defects under this warranty and are not covered in any way by this warranty.

Chore-Time shall not be liable for any **Consequential** or **Special Damages** which any purchaser may suffer or claim to have suffered as a result of any defect in the product. "**Consequential**" or "**Special Damages**" as used herein include, but are not limited to, property damage, lost or damaged products or goods, costs of transportation, lost sales, lost orders, lost income, increased overhead, labor and incidental costs and operational inefficiencies.

THIS WARRANTY CONSTITUTES CHORE-TIME'S ENTIRE AND SOLE WARRANTY AND CHORE-TIME EXPRESSLY DISCLAIMS ANY AND ALL OTHER WARRANTIES, INCLUDING, BUT NOT LIMITED TO, EXPRESS AND IMPLIED WARRANTIES AS TO MERCHANTABILITY, FITNESS FOR PARTICULAR PURPOSE SOLD AND DESCRIPTION OR QUALITY OF THE PRODUCT(S) FURNISHED HEREUNDER.

*TURBO™ Fans include: (1) 10" Tube Fans; (2) 14", 18" and 24" Hood and Door Fans; and (3) 24", 36" and 48" Cone Fans and Grill Fans.

**CHORE-TIME EQUIPMENT, a Division of CTB, INC.
P.O. Box 2000, Milford, Indiana, USA, 46542-2000**

Table of Contents

Topic	Page	User*
Chore-Time TURBO™ Fan Extended Warranty	2	C
Support Information	4	C,D,I
Distributor and Installer Information	4	C,D,I
Safety Information	5	C,I
Safety–Alert Symbol.	5	
Signal Words.	5	
DANGER: Electrical Hazard.	5	
Tools Required for Installation	5	I
Decal Location	6	C,I
Planning the Installation	7	C,I
Installation Instructions	8	I
Fan Installation	8	
Installing the Cone or Grill to the Fiberglass Fan.	9	
Wiring	10	
Shutter Installation	11	
Maintenance	12	C
Motor Specifications and Part No.	12	C,I
Fan Parts List	13	C
Direct Drive TURBO™ Fan	13	
Plastic Shutter	14	

*Legend: C = Customer (end user), D = Distributor (sales), I - Installer of equipment

Support Information

Chore-Time TURBO™ Cone & Grill Fans are designed to be used as exhaust fans in corrosive environments. The primary components are made from plastic or stainless steel materials. Using this equipment for any other purpose or in a way not within the operating recommendations specified in this manual will void the warranty and may cause personal injury.

This manual is designed to provide comprehensive planning, installation, operation, and parts listing information. The Table of Contents provides a convenient overview of the information in this manual. The Table of Contents also specifies which pages contain information for the sales personnel, installer, and consumer (end user).

IMPORTANT: CE stands for certified Europe. It is a standard which equipment must meet or exceed in order to be sold in Europe. CE provides a benchmark for safety and manufacturing issues. **CE is required only on equipment sold in Europe.**

Chore-Time Equipment recognizes CE Mark and pursues compliance in all applicable products. *Fill in the CE-Mark serial number in the blank space provided for future reference.*

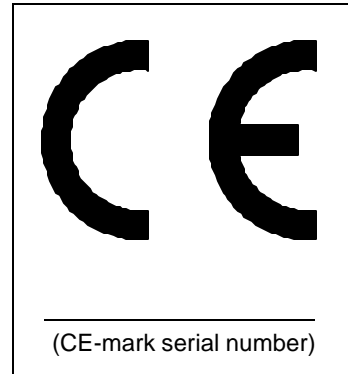

Distributor and Installer Information

Please fill in the following information about your Product.
Keep this manual in a clean, dry place for future reference.

Distributor's Name _____

Distributor's Address _____

Distributor's Phone _____ **Date of Purchase** _____

Installer's Name _____

Installer's Address _____

Installer's Phone _____ **Date of Installation** _____

System Specifications _____

Safety Information

Caution, Warning and Danger Decals have been placed on the equipment to warn of potentially dangerous situations. Care should be taken to keep this information intact and easy to read at all times. Replace missing or damaged safety signs.

Using the equipment for purposes other than specified in this manual may cause personal injury and or damage to the equipment.

Safety–Alert Symbol

This is a safety–alert symbol. When you see this symbol on your equipment, be alert to the potential for personal injury. This equipment is designed to be installed and operated as safely as possible...however, hazards do exist.



Signal Words

Signal words are used in conjunction with the safety–alert symbol to identify the severity of the warning.

DANGER..... indicates an imminently hazardous situation which, if not avoided, **WILL** result in death or serious injury.



DANGER

WARNING indicates a potentially hazardous situation which, if not avoided, **COULD** result in death or serious injury.



WARNING

CAUTION..... indicates a hazardous situation which, if not avoided, **MAY** result in minor or moderate injury.



CAUTION

DANGER: Electrical Hazard

Disconnect electrical power before inspecting or servicing equipment unless maintenance instructions specifically state otherwise.

Ground all electrical equipment for safety.

All electrical wiring must be done by a qualified electrician in accordance with local and national electric codes.

Ground all non-current carrying metal parts to guard against electrical shock.

With the exception of motor overload protection, electrical disconnects and over current protection are not supplied with the equipment.

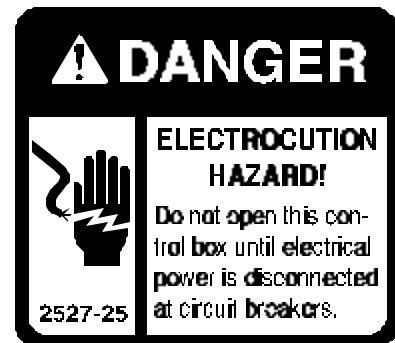

Tools Required for Installation

1. Regular Slotted Screwdriver
2. Wire Cutters
3. Wire Strippers
4. Adequate Electrical Wire
5. Electrical Drill & Drill Bits
6. Another person to help

Decal Location

This diagram shows the proper location of the safety decal as shipped from the factory. Replace damaged or missing decals. Make sure the decals can be easily seen at all times.

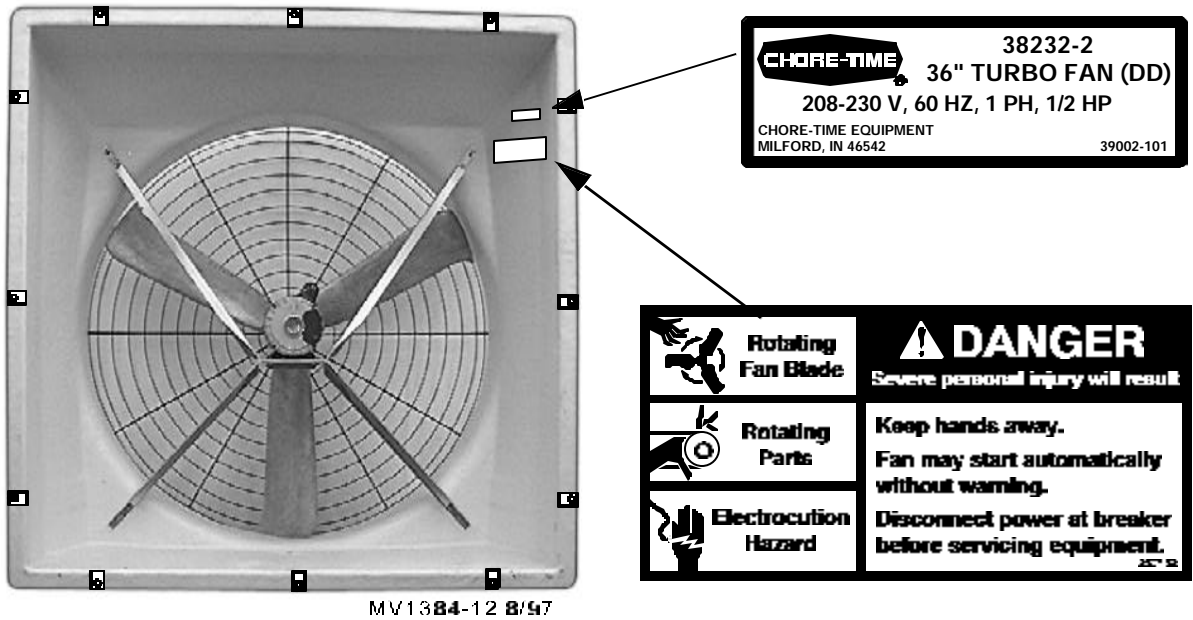

Planning the Installation

Carefully plan the installation.

Dimensions are provided for the 36" TURBO™ Fans with Cones (**Figure 1**) and without cones (**Figure 2**). Be sure to allow enough space to install fans without interfering with other fans or equipment that may be installed at a later date.

Note: See page 8 for framed opening size.

Important: Cones are wider than the actual opening cut into wall. Thus, dimension "C" must be no less than that listed in chart below.

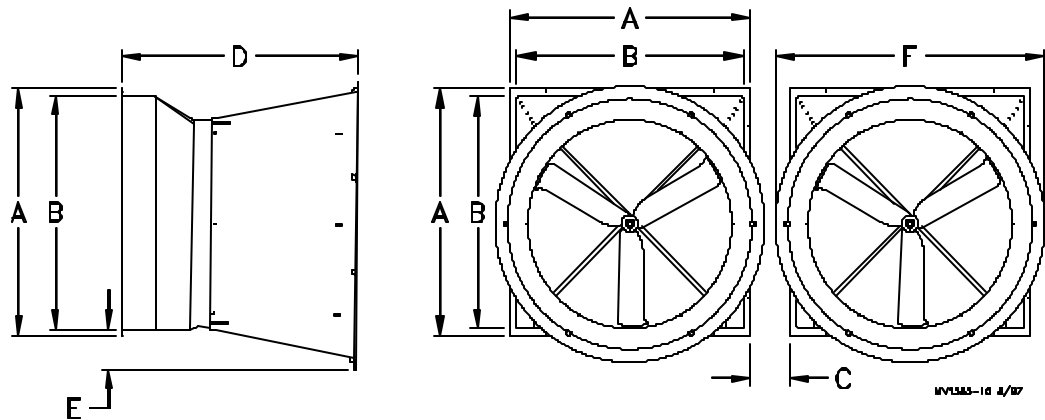

Figure 1. Planning and Layout Diagram for Cone Fans

A	B Rough Frame Opening	C Minimum	D	E	F
45.38" (115.27 cm)	43.00" (109.22 cm)	12.00" (30.48 cm)	47.00" (119.38 cm)	6.85" (17.40 cm)	52.38" (133.05 cm)

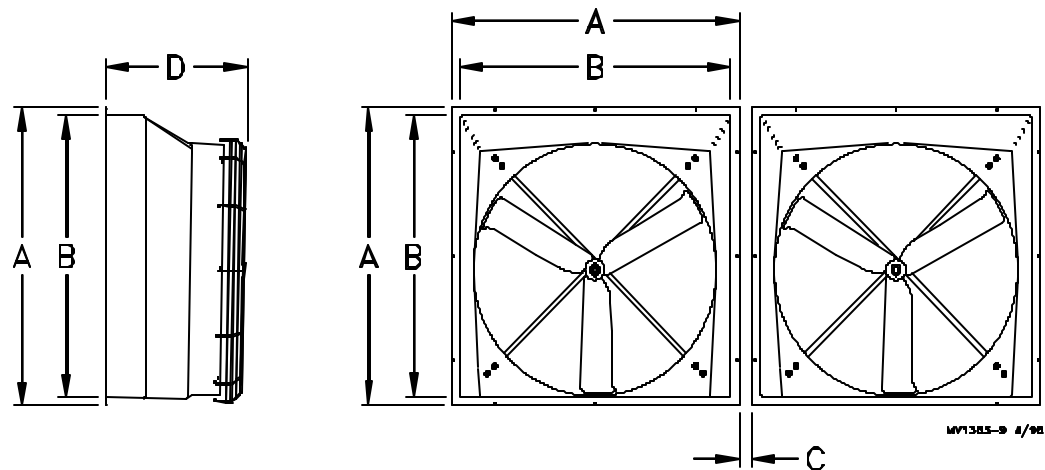

Figure 2. Planning and Layout Diagram for Grill Fans

A	B Rough Frame Opening	C Minimum	D
45.38" (115.27 cm)	43.00" (109.22 cm)	0" (0.00 cm)	27.00" (68.58 cm)

Installation Instructions

Fan Installation

1. Cut a opening in the wall to house the fan—the required wall opening is provided in the chart below. **See Figure 3.**
2. Construct a frame in the opening of the wall for the fan using 2" x 6" (50 x 152 mm) lumber—not supplied. Make sure framing is square and level. Fan assembly will set on the bottom framing member.

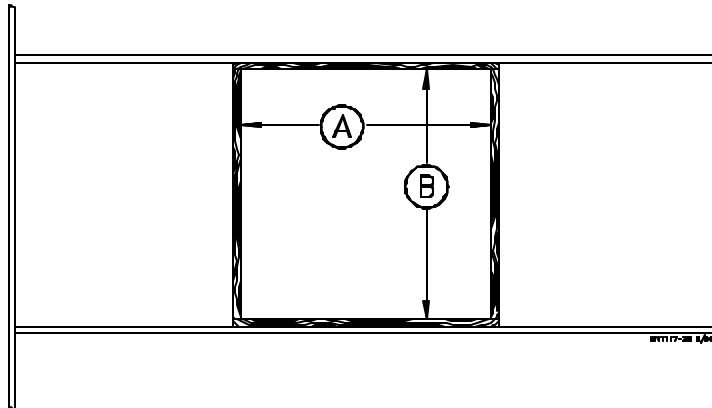
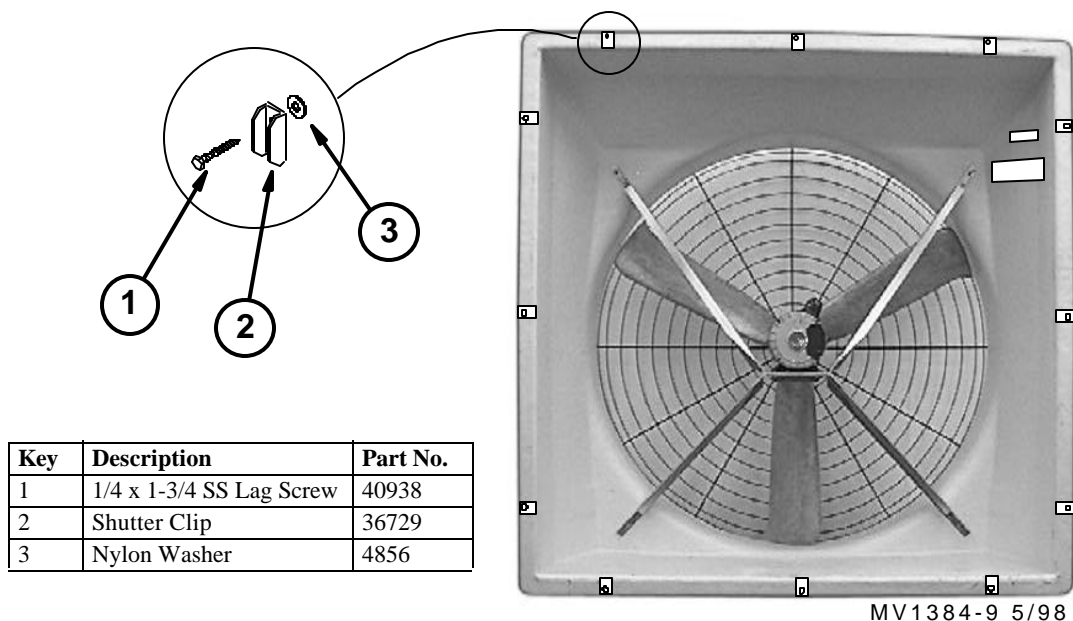

Figure 3. Framing Diagram

Minimum Dimension	
A	B
43.00" (109.22 cm)	43.00" (109.22 cm)

3. Insert the Fan Assembly in the wall opening and secure using the (12) 1/4 x 1-3/4" Lag Screws, Shutter Clips, and Nylon Washers provided. The Shroud is pre-drilled (3 holes per side). The hardware must be installed as shown in **Figure 4** below. This allows for rotation of the Shutter Clips when installing Shutter



MV1384-9 5/98

Figure 4. Fan Assembly

Installing the Cone or Grill to the Fiberglass Fan

Fiberglass Cone Fan:

1. Slide the Cone onto the Shroud—the Shroud fits inside the Cone. **See Figure 5.**
4" slots are cut into the edge of the cone to allow expansion as the cone is slide onto the shroud.

Align the holes in the Cone with the slots in the Shroud.

Insert the (6) Wafer Head Bolts from inside the Shroud through the Cone, place the Nylon Washers on the Wafer Head Bolts, and thread the Nylon Nuts onto ends of the Wafer Head Bolts.

2. Snap the Cone Grill into the slots on the outlet end of the Cone

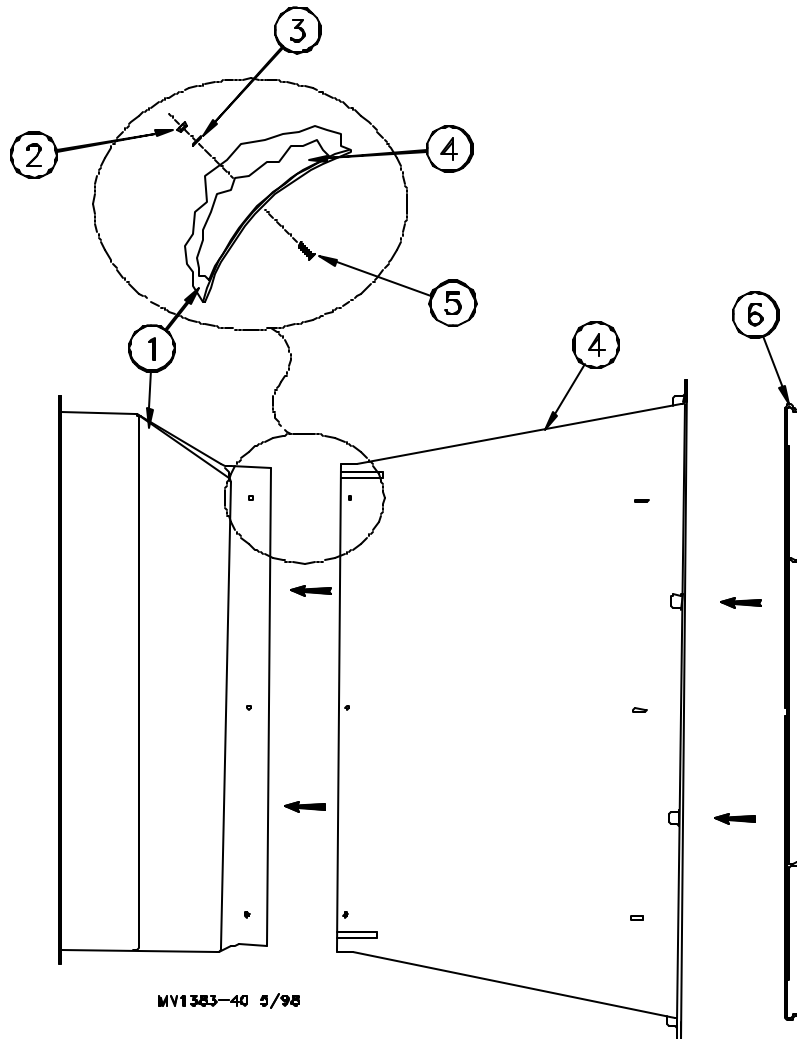

Figure 5. Cone Installation

Key	Description	Part No.
1	Shroud	38590
2	1/4-20 Nylon Hex Nut	8916
3	Nylon Washer	4856
4	Cone	38267
5	1/4-20 x 7/8 Wafer Head Bolt	40775
6	Cone Grill	35228

Fiberglass Grill Fan:

1. Align the holes in the Grill with the slots in the Shroud.
2. Insert the (6) Wafer Head Bolts from inside the Shroud through the Grill, place the Nylon Washers on the Wafer Head Bolts, and thread the Nylon Nuts onto the ends of the Wafer Head Bolts.

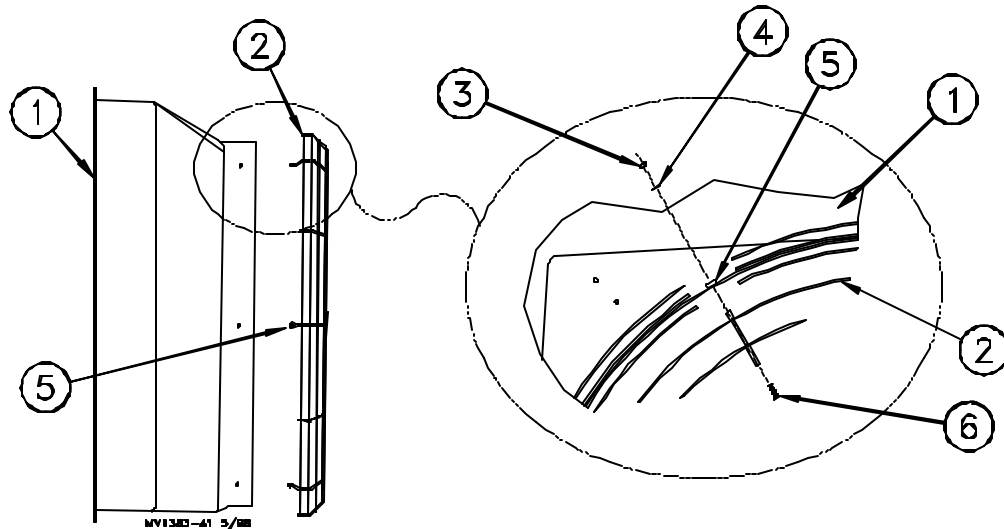

Figure 6. Grill Installation

Key	Description	Part No.
1	Shroud	38590
2	Shroud Grill	37920
3	1/4-20 Nylon Hex Nut	8916
4	Nylon Washer	4856
5	Shroud Grill Mounting Loop	
6	1/4-20 x 7/8 Wafer Head Bolt	40775

Wiring

1. See Wiring diagram on Motor for Motor electrical connections. Follow local, state, and national electrical codes for wiring
2. Install an electrical disconnect within reach of each Fan.
3. Route the motor cord (not supplied) toward the upper left corner of the Fan and attach the cord to the Motor Mount using the three Cable Ties—included in the hardware package.

Note: If an Aluminum Shutter will be installed, route the motor cord through the Rubber Grommet—included in the hardware package see Figure 7.

Some installations may require an exit hole for the motor cord to be drilled in the side of the Shroud. These installations must have electrical wires routed through conduit.

Note: Make sure the conduit or wires do not interfere with the Fan Blades or Shutter operation.

Shutter Installation

Plastic and Aluminum Shutters are available for the 36" Fans. Installation is identical except where noted. See below.

1. If you have a Plastic Shutter—cut a 3/8" slot in the upper left flange of the Shutter frame in order to route the electrical cord out the back.
2. If you have an Aluminum Shutter, route the electrical cord through the notch in the top of the Shutter Frame. Make sure the Grommet is installed correctly in the notch in the Shutter Frame. See Figure 7
3. Position the Shutter, centered in the Fan Shroud, and rotate the Shutter Clips to lock the Shutter in place. Check the Shutter for proper operation—the shutter must be able to open and close freely without obstructions.

Note: Make sure the electrical conduit and wire does not interfere with the Fan Blades or Shutter operation.

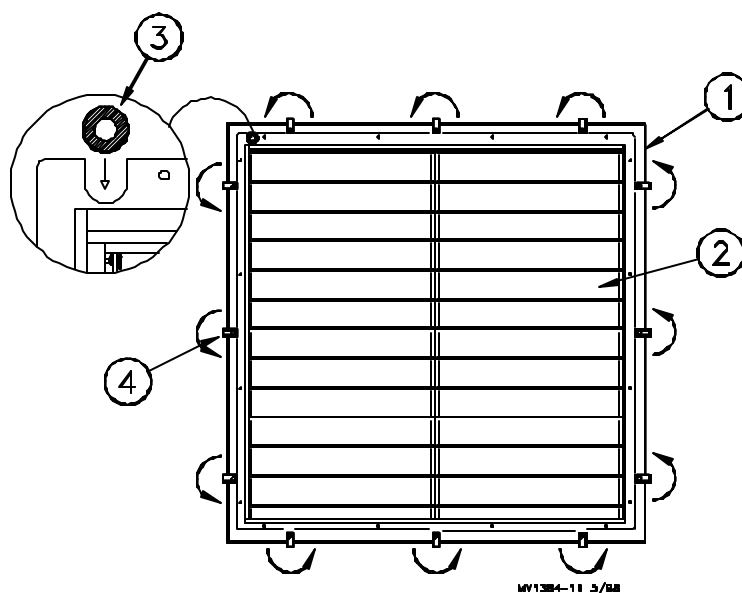

Figure 7. Shutter Installation

Key	Description	Part No.
1	Shroud	38590
2	Shutter (plastic) Shutter (aluminum)	38027 38259
3	Grommet (aluminum shutter only)	7256
4	Shutter Clip	36729

Maintenance



Service and maintenance of fans should be done only by a qualified technician.

Disconnect Power prior to maintaining or cleaning the fan! The fan may start automatically causing injury or death.

1. Keep the fan clean for maximum life and best performance.
2. Clean Shutter, Cone and Shroud for maximum life and performance.
3. The Fiberglass Fans are shipped with the Danger Decal fastened to the Fan Shroud. Always keep the Decal clean and readable.

If the Decals becomes damaged or unreadable, order replacement Decals immediately.

Clean the Shroud at the approximate location where the Decal will be placed.

Peel the backing off the Decal and affix it to the Shroud.

Motor Specifications and Part No.

Fan Specifications (assembled)		Motor Specifications				
Description	*Part No.	Voltage	HZ	Phase	HP	Motor P/N
Fiberglass Cone	38265-362X	208/230	60	1	.5	37337
	38265-364X	208/230-460	60	3	.5	38911
Grill	38947-362X	208/230	60	1	.5	37337
	38947-364X	208/230-460	60	3	.5	38911

* Replace the "X" in fan P/N with "1" for an aluminum Shutter, "2" for a plastic shutter.

Important!

Chore-Time Equipment strongly recommends that a good alarm system should be installed in confinement buildings to warn of power failure and high temperature.

Chore-time Equipment also recommends that an alternate power source be available for confinement buildings in case of power failure.

Fan Parts List

Direct Drive TURBO™ Fan

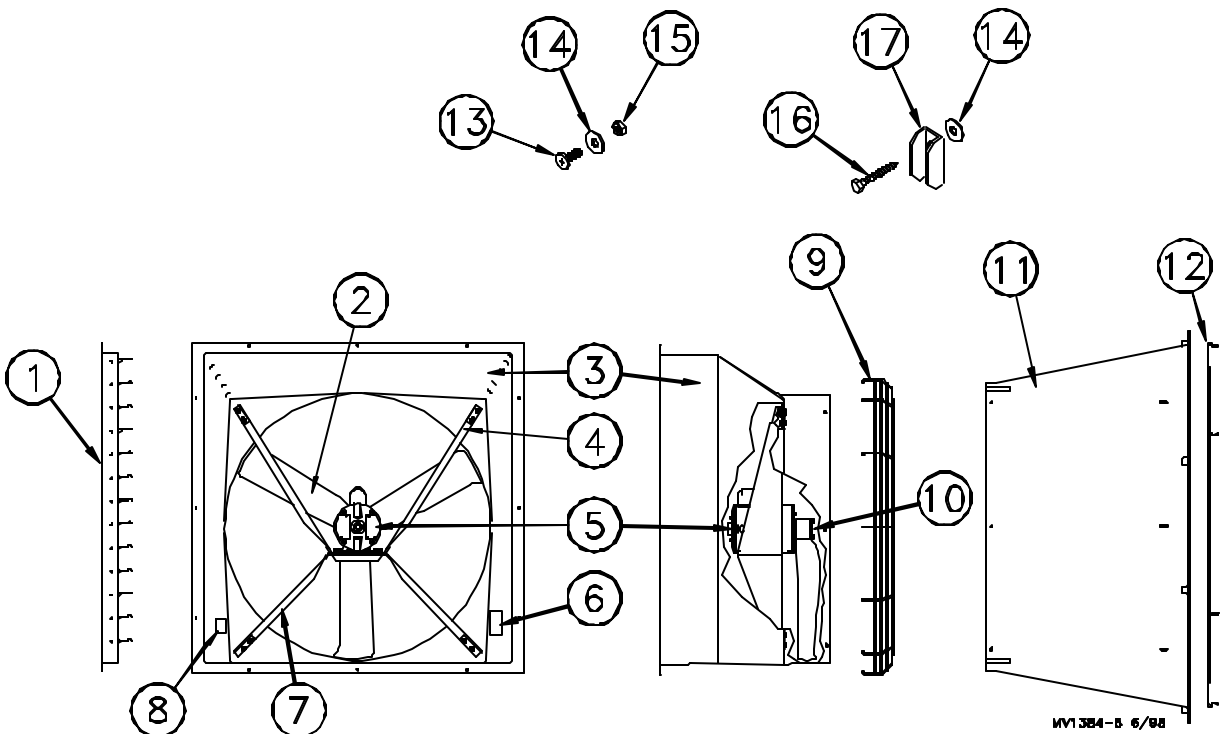

MV1384-B 6/88

Item	Description	Part No.
1*	Shutter (plastic)	38027
	Shutter (aluminum)	38259
2	Cast Aluminum Blade	38902
3	Fiberglass Shroud	37913
4	Fan Upper Motor Mount	37738
5	Motor	*
6	Danger Decal	2527-52
7	Lower Motor Mount	37739
8	Identification Decal	—
9	Shroud Grill	37920
10	Taper Lock Hub	38907
11	Plastic Outlet Cone	38267
12	Cone Grill	35228
13	1/4-20 x 7/8 Wafer Head Bolt	40775
14	Nylon Washer	4856
15	1/4-20 Nylon Hex Nut	8916
16	1/4 x 1-3/4 SS Lag Screw	40938
17	Shutter Clip	36729

Notes: * See page 12 for part numbers.

Plastic Shutter

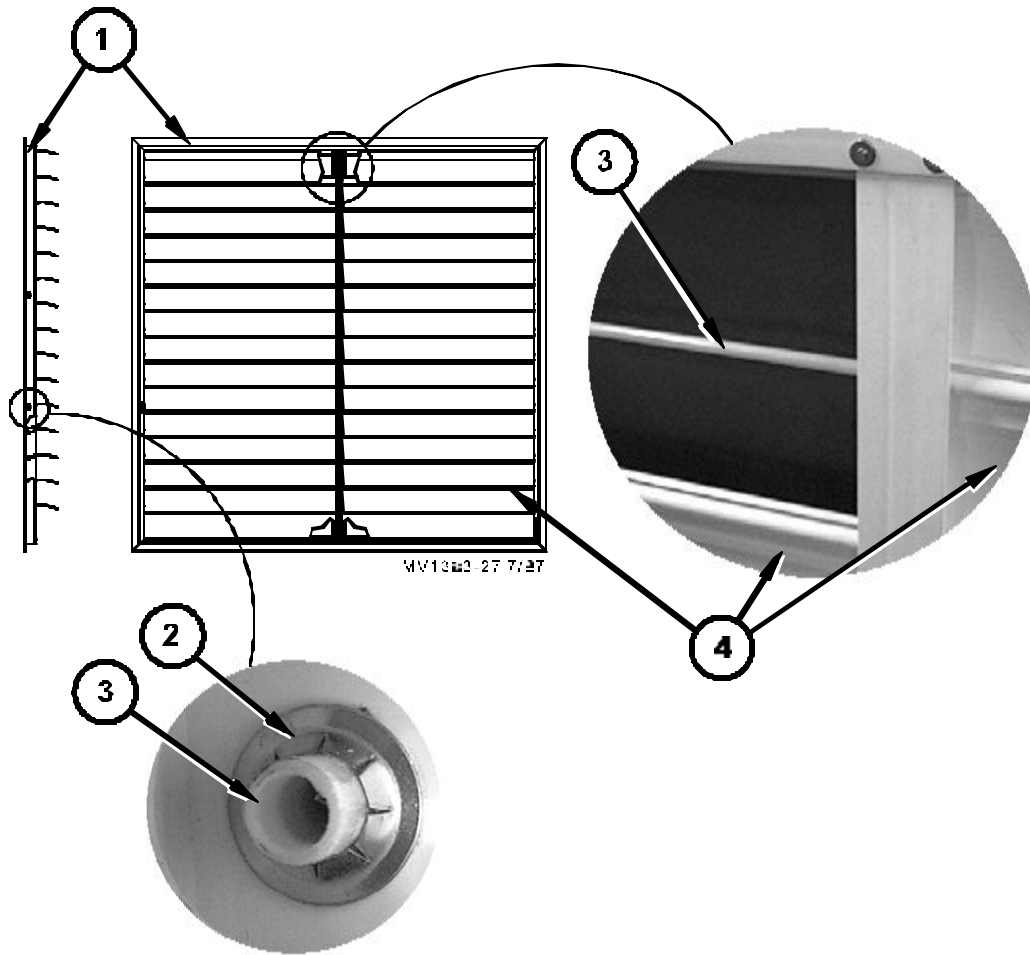

Item	Description	Part No.
1	Shutter (plastic)	38027
2	Push Nut, 1/4"	38032
3	Shutter Rod Pivot	38702-2
4	Shutter Louver	38038-2

This Page Intentionally Left Blank



**Made to work.
Built to last.**

Revisions to this Manual

Page No.	Description of Change
--	Removed 48" Fan information, added more detailed information throughout the manual

Contact your nearby Chore-Time distributor or representative for additional parts and information.

**CTB, Inc.
P.O. Box 2000
Milford, Indiana 46542-2000 U.S.A.
Phone: 219-658-4101 • E-Mail: ctb@ctbinc.com**

Printed in the U.S.A